

NEW



## SKID STEER LOADER AND COMPACT TRACK LOADER | RANGE

215 / 270 / 300 / 215T / 270T / 300T / 325T

Operating weight: 7,253-12,364 lb (3,290-5,608 kg) Gross rated power: 74 hp (55 kW)





## THE RANGE

### JCB SKID STEER AND COMPACT TRACK LOADERS FOR EVERY APPLICATION

JCB, the world's largest privately-owned manufacturer of construction and agricultural equipment, offers a range of 7 skid steer and compact track loaders spanning small-platform and large-platform "Hi-Viz" models, with vertical lift capabilities.

JCB skid steers are equipped with a 74 hp (55 kW) engine and the iconic JCB Powerboom™ with side-door entry. They are stronger and safer than conventional machines, and deliver the power, performance and reliability that today's operators and fleet managers demand.

In addition to the JCB machines detailed in this brochure, ask your JCB dealer or visit [www.jcb.com](http://www.jcb.com) to learn about the JCB Teleskid. As the world's only skid steer and compact track loader with a telescoping boom; Teleskid lifts higher, reaches further and digs deeper than any skid steer on the market.





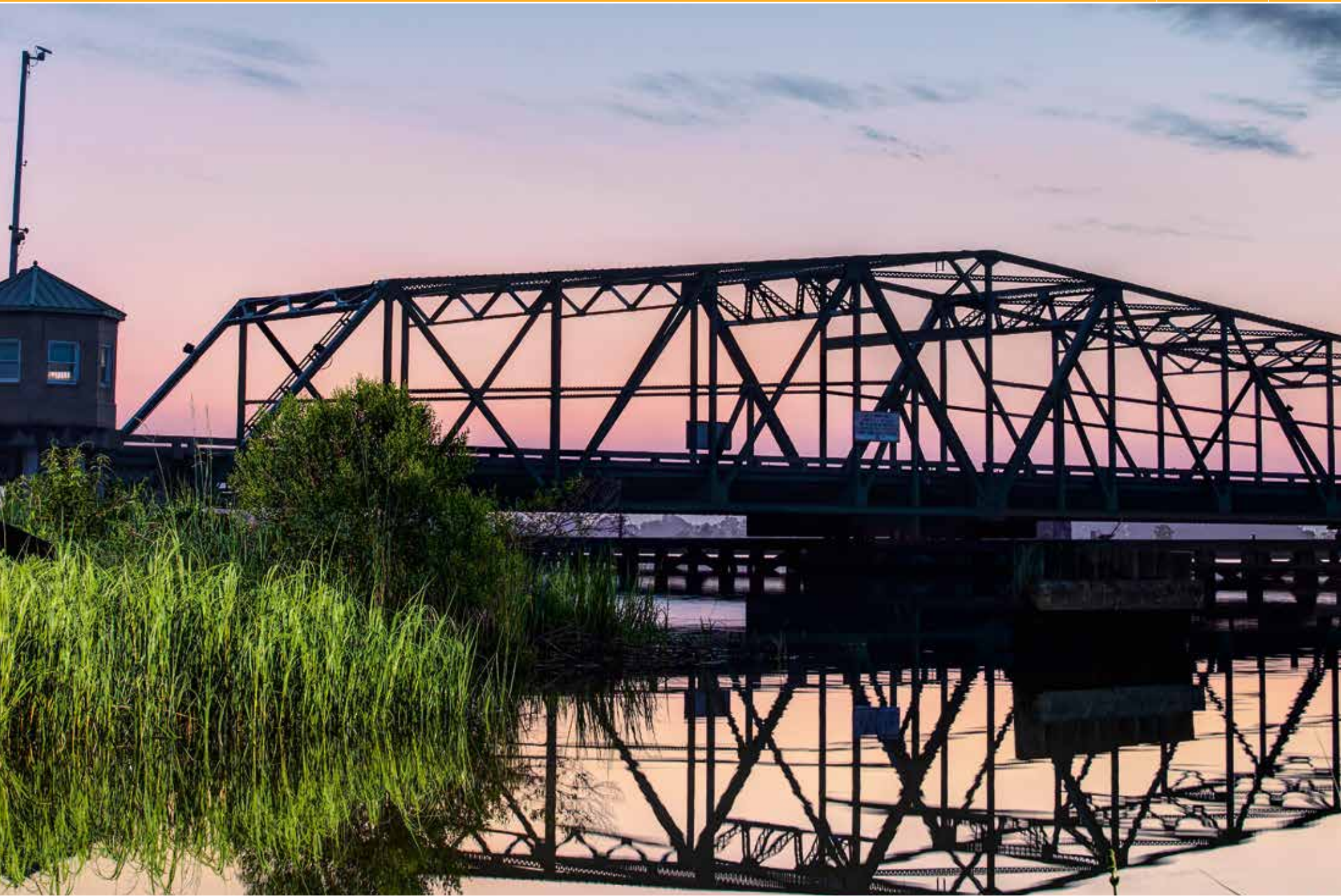



# STRENGTH AND DURABILITY

JCB HAS EARNED ITS REPUTATION FOR STRENGTH AND DURABILITY, AND JCB SKID STEERS AND COMPACT TRACK LOADERS ARE BUILT TOUGH TO HANDLE ANY APPLICATION OR CONDITIONS.

## Structural strength.

1 A fully-welded chassis provides a rigid structure for maximum strength and reduced weight. For consistent performance on demanding terrain, JCB skid steer and compact track loaders feature a solid undercarriage with cast steel, triple-flanged rollers.

2 JCB rams utilize a keyhole casting design for structural strength and durability.

A large cross-member on the chassis increases overall strength and supports the Powerboom™, with either a standard mechanical or optional powered quick hitch.

3 Wheeled models feature durable, forged steel axles and a strengthened drive chain, for trouble free operation in all conditions.

4 The fuel tank is mounted inside the loader tower for maximum protection, and is equipped with an easily accessible drain port. The optional fuel cap protection plate prevents debris from gathering around the neck of the cap.





**Built to last.**

6 The iconic JCB Powerboom™ boasts tapered pivot pins and 20 percent more steel than conventional twin-arm skid steer designs. The result is greater rigidity for less wear, longer life and improved retention of material in the bucket.

6 The JCB Powerboom™ provides safe internal routing for hydraulic hoses, for maximum protection from impact and other damage.

7 The quick hitch comprises high-tensile steel and high-strength welds for longer life, and features a fully-enclosed tilt cylinder to eliminate debris infiltration on large platform models.

For extra support and greater breakout force, JCB skid steers have the largest quick hitch pivot pins in the industry, and increased pivot pin diameter on the boom.

8 JCB's stringent test programs include prolonged high-stress loading of the chassis, boom and other key components, as well as cold climate testing and repeated transmission use over thousands of cycles.





# POWER AND PERFORMANCE

WITH PLENTY OF POWER AND VERSATILE FEATURES, JCB SKID STEER AND COMPACT TRACK LOADERS SET NEW STANDARDS FOR EFFICIENCY AND PRODUCTIVITY.

## Versed in versatility.

**1** Unlike conventional steer cooling systems, the JCB engine cooling system pulls cool, clean air from above and forces hot air out through the sides and rear, away from the operator. The result is improved, efficient cooling, even in extreme conditions.

**2** An industry-standard quick hitch provides quick and efficient coupling for all JCB attachments and any brand of skid steer attachments on the market.

**3** The standard hydraulic circuit on JCB small-platform skid steer and compact track loaders has a flow rate of 18.5 gpm. For large platform machines, the standard hydraulic circuit flow rate is 24 gpm. A high-flow option, up to 33 gpm (depending on machine size), is available for maximum attachment versatility.

**4** Optional counterweight packages are available on 215 and 215T for increased rated operating capacity (ROC), to meet individual requirements.



**Maximum output.**

5 The 300 and 300T models feature variable displacement piston pump hydraulics for faster cycle times and smoother multi-functioning.

6 Parallel lift helps to keep loads level throughout the lift cycle; ideal for carrying palletized loads and positioning loads with forks or attachments.

7 JCB's Smoothride System (SRS) allows the boom and load to move independently from the chassis, for improved load retention, operator comfort and, ultimately, faster loading cycles and journey times.

8 The minimal footprint of the JCB skid steer and compact track loader range, combined with 360-degree pivot capability, allows for easy maneuvering within confined job sites.



Vertical lift capability provides maximum lift capacity at maximum height and reach, making it the right choice for load and carry operations, including fork work, heavy construction and landscaping.



5



6



7



8



# THE WORLD'S SAFEST

WITH A WIDE-OPENING SIDE DOOR FOR SAFE ENTRY AND EXIT, OPERATORS NO LONGER NEED TO CLIMB OVER LARGE ATTACHMENTS OR UNDER AN UNSUPPORTED BOOM.

## All around visibility.

1 Operators of JCB skid steer and compact track loaders, equipped with JCB's Powerboom™, enjoy 60 percent better visibility around the machine than users of conventional twin-arm machines.

2 The low boom profile on large-platform "Hi-Viz" models allows excellent visibility to both sides of the machine, as well as to the quick hitch and the tracks or wheels.

Flat glass is easy and comparatively inexpensive to replace, if needed. A mesh option is also available to suit specific applications.

The side-mounted windshield wiper improves visibility to the quick hitch and attachment for improved productivity.

3 With no requirement for the rear torque tube found on conventional machines, operators of JCB vertical lift models benefit from even greater rear visibility. Additionally, a standard-fit rear view mirror enhances rearward visibility.





## Safer by design.

**4** A wide-opening door and large grab handles enable easy and safe entry and exit, eliminating crush and slip hazards associated with front-entry machines.

**5** Emergency exit from JCB skid steer and compact track loaders is via the front of the machine, as opposed to the small rear window on conventional twin-arm designs.

A reverse alarm is standard, and a white noise reverse alarm is available as an option.

An optional keyless immobilizer allows the operator to enter a four-digit PIN to start the machine, instead of a keyed ignition.

**6** The optional electric quick hitch is fitted with a single-point lock-and-unlock flag for optimal visibility, to ensure that the attachment is safely locked/unlocked.

**7** Tasks such as loading a truck or changing attachments are simplified due to excellent visibility to the cutting edge of the bucket and quick hitch.





# TOTAL COMFORT AND CONTROL

WITH EASY SIDE-DOOR ENTRY, THE LARGEST CABS ON THE MARKET, ELECTRIC CONTROLS AND ADJUSTABLE JOYSTICK CONTROLS, JCB SKID STEERS AND COMPACT TRACK LOADERS OFFER UNRIVALLED COMFORT FOR MAXIMUM PRODUCTIVITY.

## Industry-leading operator environment.

**1** The latest JCB cab is in a class of its own for ergonomics and operator comfort. The operator environment on large-platform JCB machines is 33 percent larger than the competition; cabs on small-platform JCB skid steers are 46 percent larger than competing machines.

**2** JCB cabs feature a handy storage space and 12-volt power socket for charging mobile phones and other devices.

**3** JCB skid steers and compact track loaders have one of the best ventilation systems in the industry, thanks to three cab ventilation filters and an external panel cover. Air conditioning is available as an option, to provide the perfect, controllable cabin environment.

Deflection plates in the engine bay direct heat out of the rear door and away from the operator.

**4** All JCB skid steer and compact track loader cabs are fitted with a sliding window on the left side for improved ventilation and communication with co-workers.





**Total control.**

5 JCB's myCHOICE control software allows the responsiveness of the joysticks to be adjusted. Three settings allow operators to tailor the sensitivity of joystick movement to match the way they work. The new software enables one-touch unlock operation for ease of use.

6 Instrumentation at the operator's eye level on the left side of the cab includes the integrated standard radio and climate control functions. This position limits exposure to dirt and dust to avoid damage.

7 On the right side of the cab, an easily accessible control panel features machine diagnostics, electric hand throttle and ignition switch.

8 ISO or H-pattern controls are available to suit operator preferences. ISO (single joystick operation) is standard; an ISO-H pattern option is available.

9 The diagnostics, electronic throttle and ignition switch are within easy reach, to minimize fatigue. An optional 7-way multi-function joystick (included with high-flow hydraulics option) makes it easy to control a wider range of attachments.

The radio features an AUX port that is compatible with mobile phones and other devices.

Operators can control power, torque and tractive effort, for maximum productivity.





## A SOUND INVESTMENT

**JCB SKID STEERS AND COMPACT TRACK LOADERS ARE EFFICIENT TO USE, OWN AND OPERATE. SUPERIOR BUILD QUALITY, GREAT FUEL EFFICIENCY AND LOW RUNNING COSTS ENSURE HIGH RESALE VALUES AND MAXIMUM RETURN ON INVESTMENT.**

### JCB EcoMAX.

**1** JCB large-platform skid steers and compact track loaders are equipped with JCB EcoMAX engines that require no diesel particulate filter (DPF), no diesel exhaust fluid (DEF) and no engine aftertreatment. In addition to eliminating productivity-sapping engine regeneration, JCB EcoMAX engines offer simplified servicing for lower operating costs and less downtime.

JCB EcoMAX engines produce peak torque at low engine speeds for fuel-efficient matching of the transmission and hydraulics.

The Tier-4 Final EcoMAX engine uses up to nine percent less fuel than Tier-3 units, for a significant saving in operating costs.

### JCB Diesel by Kohler.

**2** Small platform JCB skid steers and compact track loaders are equipped with the JCB Diesel by Kohler KDI Tier-4 Final engines, featuring a maintenance-free diesel oxidation catalyst (DOC) and offering improved torque and fuel efficiency.

JCB Diesel by Kohler engines boast an advanced combustion system that significantly reduces emissions and fuel consumption.

Like the JCB EcoMAX unit, JCB Diesel by Kohler engines require no DEF, no DPF, and no exhaust aftertreatment, for reduced operating costs and maintenance down time.

JCB engines produce high horsepower and torque at a lower RPM, and are matched to the hydraulic system for optimal efficiency.





**More for your money.**

3 The hydraulic, variable-speed cooling fan automatically responds to the engine speed; as RPMs increase or decrease, so too does fan speed, for improved productivity.

4 An optional, reversible fan purges debris from the rear screen, reducing maintenance downtime and increasing productivity in dirty, dusty conditions. Reverse airflow can be set to auto-mode, or engaged manually by the operator from inside the cab as required.

5 JCB large platform skid steer and compact track loaders are equipped with an air intake scavenge system as standard, minimizing debris build-up in the air filter to extend service intervals.

A belly plate underneath the machine protects it from impact damage.

6 An optional 2-speed transmission enables JCB skid steers and compact track loaders to achieve faster travel and cycle times.

7 Transport weights range from just 7,253 lb (3,290 kg), allowing many JCB skid steer models to be towed behind a standard pickup truck, often without need for a commercial driver's license (subject to local regulations).





## SIMPLE SERVICING

JCB SKID STEER AND COMPACT TRACK LOADERS ARE LOW-MAINTENANCE AND EASY TO SERVICE, MAKING THEM AFFORDABLE, EFFICIENT AND HIGHLY PRODUCTIVE.

### Unrivalled serviceability.

**1** All daily checks and greasing can be performed at ground level. Daily maintenance points, pre-filters, oil and air filters are easy to access via a large, rear service door. The door is recessed for protection from potential impact damage.

**2** JCB's tilting cabs can be operated by one person and opened in just a few minutes, to provide access for more detailed maintenance. On large-platform models, this can be done without raising the boom.

**3** O-ring face seal hydraulic fittings reduce leaks and maintenance downtime.

To facilitate a quick clean out with a power washer, the engine bay is easily accessible. JCB machines also feature flat floors, with no hard-to-clean foot wells, for speedy turnaround times.

If access to major components is required, the cab can be tilted in less than five minutes.





## VALUE ADDED

WHATEVER YOU NEED AND WHEREVER YOU ARE, JCB'S DEPENDABLE NORTH AMERICAN DEALER NETWORK IS HERE TO MAKE SURE YOUR MACHINERY PERFORMS TO ITS FULL POTENTIAL.



1

1 JCB Technical Support Service provides instant access to factory expertise, day or night.

JCB's Finance team is always on hand to provide fast, flexible, competitive quotes.

2 The global network of JCB Parts Centers is a model of efficiency. Genuine JCB parts are designed to work in perfect harmony with your machine for optimum performance and productivity.



2

3 JCB Yellow Shield offers comprehensive extended warranties and service agreements, as well as service-only or repair and maintenance contracts. JCB maintenance teams offer competitive labor rates and no-obligation quotes.

JCB skid steer and compact track loaders come with a 2-year, 2000-hour warranty as standard, for total piece of mind.



3

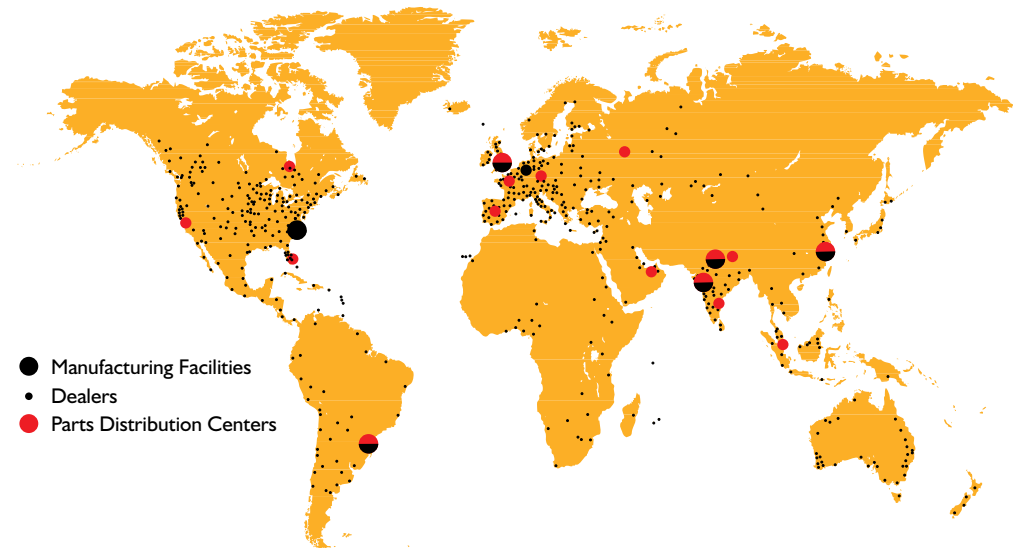

Note: JCB YELLOW SHIELD may not be available in your region. Please check with your local JCB dealer.



STATIC DIMENSIONS – SKID STEER LOADER

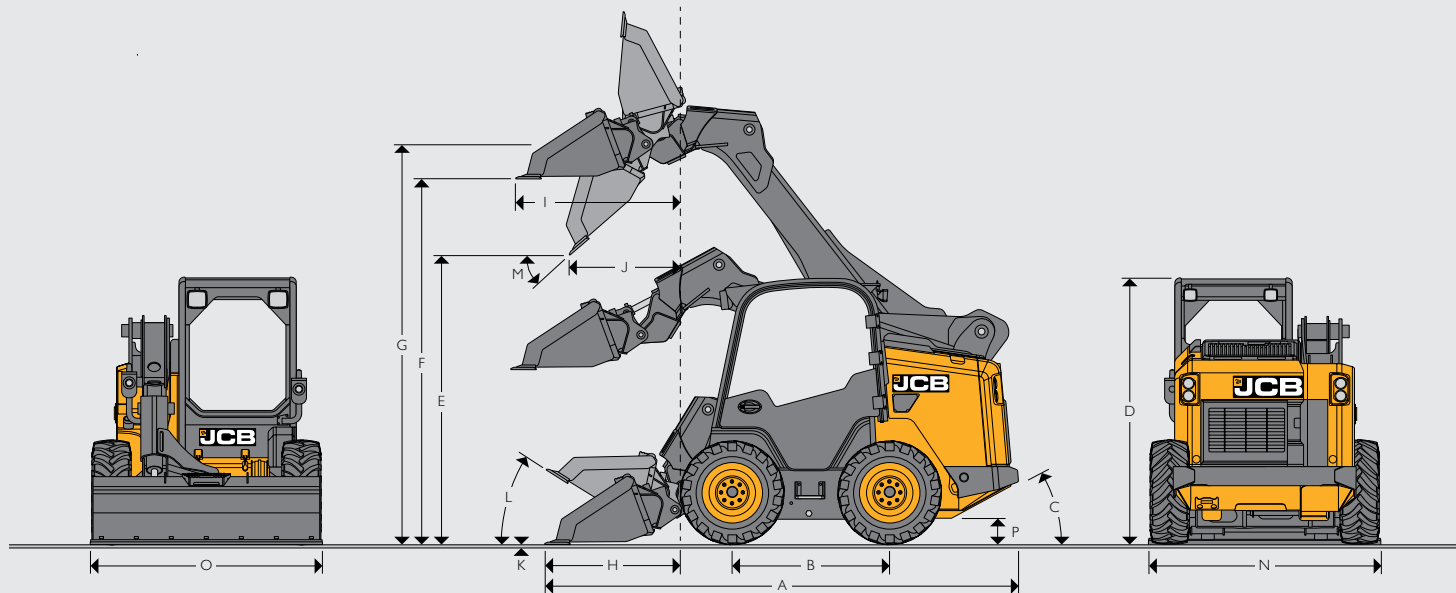

STATIC DIMENSIONS – SKID STEER LOADER

	SMALL PLATFORM		LARGE PLATFORM	
		Vertical		Vertical
<b>Lift path</b>				
<b>Machine model</b>		<b>215</b>	<b>270</b>	<b>300</b>
A Overall length	ft-in (m)	11-5 (3.49)	12-6 (3.8)	12-6 (3.8)
B Wheelbase	ft-in (m)	3-6 (1.07)	4-1 (1.25)	4-1 (1.25)
C Angle of departure	degrees	25	29	29
D Overall height	ft-in (m)	6-6 (1.98)	6-11 (2.1)	6-11 (2.1)
E Dump height	ft-in (m)	7-5 (2.26)	7-6 (2.3)	7-6 (2.3)
F Loadover height	ft-in (m)	9-4 (2.84)	9-6 (2.9)	9-6 (2.9)
G Pin height	ft-in (m)	9-10 (3.00)	10-6 (3.2)	10-6 (3.2)
H Reach @ ground level	ft-in (m)	3-3 (1.00)	3-7 (1.1)	3-7 (1.1)
I Max. reach @ full height	ft-in (m)	3-11 (1.21)	4-4 (1.3)	4-4 (1.3)
J Reach @ full height - fully dumped	ft-in (m)	2-10 (0.86)	2-11 (0.9)	2-11 (0.9)
K Dig depth clearance	in (mm)	-3/8 (-10)	-3/8 (-10)	-3/8 (-10)
L Rollback @ ground	degrees	30	30	30
M Dump angle	degrees	42	42	42
N Width over tires - standard	ft-in (m)	5-3 (1.52)	5-11 (1.8)	5-11 (1.8)
O Bucket width - standard	ft-in (m)	5-6 (1.68)	6-3 (1.9)	6-3 (1.9)
Bucket capacity - standard	yd³ (m³)	0.47 (0.36)	0.56 (0.43)	0.56 (0.43)
<b>Turning radius</b>				
Bucket corner radius	ft-in (m)	6-10 (2.09)	7-7 (2.30)	7-7 (2.30)
Quick hitch radius	ft-in (m)	3-9 (1.14)	4-11 (1.5)	4-11 (1.5)
Rear chassis radius	ft-in (m)	5-5 (1.65)	5-9.5 (1.76)	5-9.5 (1.76)
P Ground clearance	in (mm)	8.3 (210)	10 (250)	10 (250)



## STATIC DIMENSIONS – COMPACT TRACK LOADER

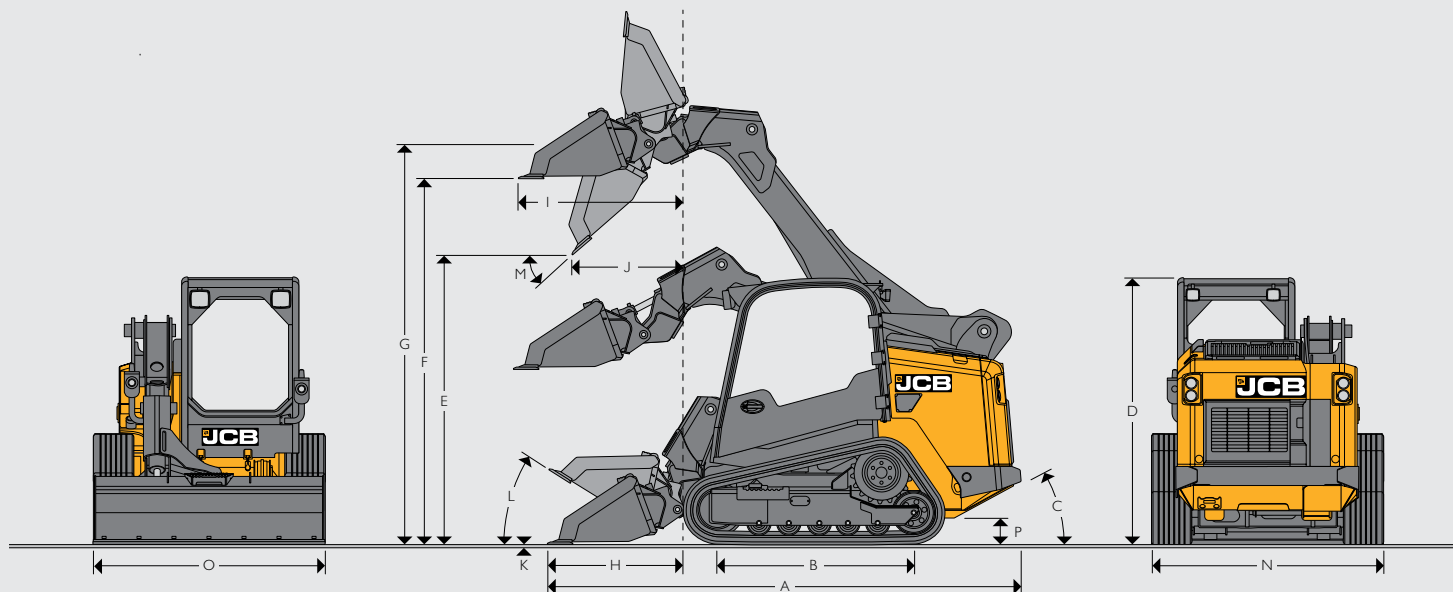

## STATIC DIMENSIONS – COMPACT TRACK LOADER

		SMALL PLATFORM		LARGE PLATFORM	
Lift path		Vertical	Vertical	Vertical	Vertical
Machine model		215T	270T	300T	325T
A	Overall length	ft-in (m)	11-5 (3.49)	12-6 (3.8)	12-6 (3.8)
B	Wheelbase	ft-in (m)	5-10 (1.78)	6-11 (2.1)	6-11 (2.1)
C	Angle of departure	degrees	27	29	29
D	Overall height	ft-in (m)	6-7 (2.00)	6-10 (2.08)	6-10 (2.08)
E	Dump height	ft-in (m)	7-6 (2.29)	7-5 (2.28)	7-5 (2.28)
F	Loadover height	ft-in (m)	9-4 (2.85)	9-5 (2.88)	9-5 (2.88)
G	Pin height	ft-in (m)	9-11 (3.02)	10-5 (3.18)	10-5 (3.18)
H	Reach @ ground level	ft-in (m)	3-3 (1.00)	3-7 (1.1)	3-7 (1.1)
I	Max. reach @ full height	ft-in (m)	4-0 (1.21)	4-3 (1.30)	4-3 (1.30)
J	Reach @ full height - fully dumped	ft-in (m)	2-9 (0.85)	2-11 (0.9)	2-11 (0.9)
K	Dig depth clearance	in (mm)	-3/8 (-10)	-3/8 (-10)	-3/8 (-10)
L	Rollback @ ground	degrees	30	30	30
M	Dump angle	degrees	42	42	42
N	Width over tires - standard	ft-in (m)	5-6 (1.68)	6-3 (1.9)	6-3 (1.9)
O	Bucket width - standard	ft-in (m)	5-6 (1.68)	6-3 (1.9)	6-3 (1.9)
	Bucket capacity - standard	yd <sup>3</sup> (m <sup>3</sup> )	0.47 (0.36)	0.56 (0.43)	0.56 (0.43)
<b>Turning radius</b>					
	Bucket corner radius	ft-in (m)	6-10 (2.09)	7-7 (2.3)	7-7 (2.3)
	Quick hitch radius	ft-in (m)	3-9 (1.14)	5-7 (1.7)	5-7 (1.7)
	Rear chassis radius	ft-in (m)	5-5 (1.65)	5-9 (1.76)	5-9 (1.76)
P	Ground clearance	in (mm)	0-9 (230)	0-9 (230)	0-9 (230)



## HYDRAULIC PERFORMANCE - SKID STEER

		SMALL PLATFORM		LARGE PLATFORM	
Machine model		215		270	
				300	
SAE Cab operating weight (no counterweight)	lb SAE (kg)	7,253 (3,290)		8,680 (3,937)	9,288 (4,213)
SAE Cab operating weight (1 pair suitcase weights)	lb SAE (kg)	7,354 (3,336)		N/A	N/A
SAE Cab operating weight (2 pair suitcase weights)	lb SAE (kg)	7,455 (3,381)		N/A	N/A
Rated operating capacity (ROC) 35% (no counterweight)	lb SAE (kg)	1,477 (670)		1,907 (865)	2,229 (1,011)
Rated operating capacity (ROC) 50% (no counterweight)	lb SAE (kg)	2,112 (958)		2,723 (1,235)	3,186 (1,445)
ROC with full counterweight	lb SAE (kg)	2,257 (1,024)		N/A	N/A
Tipping load - no counterweight	lb (kg)	4,222 (1,915)		5,448 (2,471)	6,369 (2,889)
Tipping load - full counterweight	lb (kg)	4,517 (2,049)		N/A	N/A
Loader lift capacity with shovel	lbf (kg)	4,592 (2,083)		6,056 (2,747)	6,056 (2,747)
Bucket tilt breakout force	lbf (kgf)	4,899 (2,222)		6,543 (2,968)	6,543 (2,968)

## HYDRAULIC PERFORMANCE - COMPACT TRACK LOADER

		LARGE PLATFORM		LARGE PLATFORM	
Machine model		215T		270T	
				300T	
				325T	
SAE Cab operating weight (no counterweight)	lb SAE (kg)	9,098 (4,127)	11,003 (4,991)	11,219 (5,089)	12,364 (5,608)
SAE Cab operating weight (1 pair suitcase weights)	lb SAE (kg)	9,200 (4,173)	N/A	N/A	N/A
SAE Cab operating weight (2 pair suitcase weights)	lb SAE (kg)	9,301 (4,219)	N/A	N/A	N/A
Rated operating capacity (ROC) 35% (no counterweight)	lb SAE (kg)	2,105 (955)	2,723 (1,235)	3,000 (1,361)	3,201 (1,452)
Rated operating capacity (ROC) 50% (no counterweight)	lb SAE (kg)	3,009 (1,365)	3,995 (1,812)	4,314 (1,957)	4,572 (2,074)
ROC with full counterweight	lb SAE (kg)	2,138 (970)	N/A	N/A	N/A
Tipping load - no counterweight	lb (kg)	6,016 (2,729)	7,990 (3,624)	8,627 (3,913)	9,145 (4,148)
Tipping load - full counterweight	lb (kg)	6,109 (2,771)	N/A	N/A	N/A
Loader lift capacity with shovel	lbf (kg)	4,592 (2,083)	5,807 (2,634)	5,807 (2,634)	5,807 (2,634)
Bucket tilt breakout force	lbf (kgf)	4,945 (2,243)	6,543 (2,968)	6,543 (2,968)	6,543 (2,968)

## HYDRAULICS - SMALL PLATFORM AND LARGE PLATFORM

In addition to the main hydrostatic drive pumps, there is a dedicated service pump for the loader and attachments (auxiliary hydraulics circuit standard flow on all base models).

Standard flow	215/215T	270/300/270T/300T/325T
	18.5 gpm (70 lpm) @ 2,730 RPM Main relief pressure 3,335 psi (230 bar) HYD Power Low Flow (36.0 hp)*	24 gpm (90 lpm) @ 2,300 RPM Main relief pressure 3,335 psi (230 bar) HYD Power Low Flow (46.7 hp)*
Optional auxiliary high flow	215/215T	270/270T
	26.4 gpm (100 lpm) HYD Power High Flow (51.4 hp)*	31.7 gpm (120 lpm) HYD Power High Flow (61.7 hp)*
Optional auxiliary high flow	215/215T	300/300T/325T
	30.4 gpm (115 lpm) HYD Power High Flow (59.1 hp)*	33 gpm (125 lpm) HYD Power High Flow (64.2 hp)*

- Low joystick lever efforts give excellent and easy control of transmission, loader and attachments.
- Auxiliary hydraulics are actuated on the joystick roller giving progressive control of hydraulic fluid flow for precise attachment control
- Loader arm hydraulic lines under protective steel guard on Powerboom™.
- Canister style, full flow, hydraulic oil filter.
- JCB engine oil for engine and chain case.
- JCB hydraulic oil.

\*Calculated

## CAPACITIES

		SMALL PLATFORM	LARGE PLATFORM
Hydraulic system (including tank)	gal (l)	11.5 (43.5)	14.5 (55)
Fuel tank (radial / vertical lift)	gal (l)	25.9 (98) / 24.3 (92)	27.3 (103.3)
Engine coolant	gal (l)	2.6 (10)	5.8 (22)
Engine oil min/max.	gal (l)	1.5 (5.5) / 2 (7.4)	3.2 (12) / 4.0 (15)
LH chaincase (wheeled machines only)	gal (l)	5 (19)	6.2 (23.3)
RH chaincase (wheeled machines only)	gal (l)	5 (19)	6.2 (23.3)

## TRANSMISSION

A full electro-hydraulic controlled hydrostatic transmission giving zero to maximum speed, both forward and reverse at full power. Hydraulic power management system maintains full engine power availability maximizing loader and attachment control.

Model		Single Speed	Two Speed
Travel speed 215	mph (km/h)	7.5 (12.0)	7.5 (12.0) / 11.5 (18.5)
Travel speed 270/300	mph (km/h)	6.8 (10.9)	6.8 (10.9) / 12.4 (20.0)
Travel speed 215T	mph (km/h)	6.2 (10.0)	5.6 (9.0) / 7.8 (12.5)
Travel speed 270T/300T/325T/	mph (km/h)	5.7 (9.2)	4.8 (7.7) / 7.8 (12.5)

ENGINE			
		SMALL PLATFORM	LARGE PLATFORM
		215/215T	270/300/270T/300T
Engine model		Kohler - KDI2504TCR/26A	EcoMAX TCAE-55
Displacement	in <sup>3</sup> (cm <sup>3</sup> )	151 (2474)	268 (4399)
Fuel		Diesel	Diesel
Cooling		Liquid	Liquid
Aspiration		Turbo	Turbo
<b>Gross Power @ 2400 RPM</b>			
SAE J1995	hp (kW)	74 (55)	74 (55)
<b>Gross Torque @ 1200 RPM</b>			
SAE J1995	lb/ft (Nm)	221.2 (300)	295 (400)
Starter motor	hp (kW)	2.72 (2)	5.63 (4.2)
Battery	V/Ah	12 / 109	12 / 109
Alternator	amps	100	95
Emission certification		EPA-T4F (EU St3B)	EPA-T4F (EU St3B)
Engine oil service interval hours		500	500
Variable speed hydraulically driven fan		YES	YES

TIRES / TRACKS	
TIRES	TRACKS
<b>Standard – 215</b> 10 x 16.5 - 8 PR Xtra Wall Off Road	<b>215T</b>
<b>Standard – 270/300</b> 12 x 16.5 - 10 PR Xtra Wall Off Road	12.6 in (320 mm) wide traction lug
<b>215 Available tire options</b>	<b>270T/300T/325T</b>
11 x 16.5 - 10 PR All Terrain	15.7 in (400 mm) wide traction lug
10 x 16.5 - Reinforced 2 Steel Crown, 3 Metal Shoulders Bibsteel All Terrain	<b>Available track options</b>
7 x 15 - 14 PR Extra Duty Plus Industrial	17.7 in (450 mm) wide traction lug
30 x 7.6 - 15 Solid no Aperture Extreme Industrial	
31 x 10 - 18 Solid with Aperture Brawler Heavy Duty Off Road	
33 x 10 - 20 Solid with Aperture Slick Heavy Duty	
<b>270 / 300 Available tire options</b>	
7.6 x 15 Solid Industrial Slick	
11 x 16.5 - 12 PR Xtra Wall Off Road	
12 x 16.5 - 10PR Off Road	
12 x 16.5 - Reinforced 2 Steel Crown, 3 Metal Shoulders Bibsteel All Terrain	
15.5 x 16.5 - 14 PR Off Road Flotation	
33 x 11 - 20 Solid with Aperture Brawler Heavy Duty Off Road	
36 x 22 - 20 Solid with Aperture Brawler Heavy Duty Off Road	
32 x 8.5 - 16 Solid with Aperture Heavy Duty Industrial	
33 x 10 - 20 Solid with Aperture Slick Heavy Duty Off Road	

For arduous conditions and hostile environments solid tires are recommended.

CONTROLS - ALL MODELS
JCB servo control (ISO) pattern provides all drive functions on left and loader function on right joystick. The left hand control pod pivots rearwards, providing unparalleled machine entry/exit.

STANDARD EQUIPMENT - ALL MODELS
Isolation mounted canopy. ROPS and FOPS. Restraint activated safety system. Arm rest lap bar safety feature. Centrifugal dry type engine air filter with safety element. Mechanical quick hitch. Electronic hand throttle. Two front and one rear work light. Emergency lower valve. Fuel gauge. Hydraulic park brake. Standard Flow auxiliary hydraulics. Three-way joysticks. Rear service access door. Tilting cab. Static seat in wheeled models. Mechanical suspension seat in tracked models. Float. Pod storage area. Cup holder. Power socket. Rear view mirror. Interior light. Battery isolator.

OPTIONAL EQUIPMENT - ALL MODELS
Sealed and pressurized cab with heater/defroster. Air conditioning. Mechanical and air suspension seats. Road lights. Beacon. Foot throttle. Toolkit. Self levelling. Level 2 FOPS guard. Heavy-duty rear door guard. Front screen guard. High Flow auxiliary hydraulics. Spark arrestor. Tooth guard. Powered quick hitch. Smooth Ride System. Polycarbonate screen. Radio. Twine cutter (wheeled units only). Three-inch seat belt. Creep speed. ISO/H pattern changeover. Fenders. Reversing fan. Pre-cleaner.

OPERATOR ENVIRONMENT - ALL MODELS
Full ROPS and Level 1 FOPS with optional Level 2 FOPS guard for demolition, full visual and audible warning system. Soundproofing gives noise levels complying with EC regulations. Cab access through side door due to JCB's Powerboom™ design.
<ul style="list-style-type: none"> <li>• Deluxe environment available in either open canopy, cab with heat, or cab with heat and A/C.</li> <li>• Unequalled, all-around visibility.</li> <li>• Fully-adjustable seat.</li> <li>• Retractable seat belt fitted as standard.</li> <li>• Electric over hydraulic controls with either standard (3-way) joysticks or optional JCB multi-function (7-way) joysticks.</li> </ul>

LIGHTING AND ELECTRICS
12 V, negative ground system
1,000 cold cranking amp (CCA) battery
215 /215T 100 amp alternator and electronic throttle
270/300/270T/300T/325T 95 amp alternator

Also incorporated into the instrument panel, is a warning light cluster which also has visual and/or audible alarms for: Low charge pressure, engine water temperature, blocked air filter pressure, engine oil pressure, alternator voltage. Cab mounted fuse and relay box designed to keep dirt and water out; standard battery disconnect.





**ONE COMPANY, MORE THAN 300 MACHINES.**

**SKID STEER LOADER AND COMPACT TRACK LOADER | RANGE**  
 215 / 270 / 300 / 215T / 270T / 300T / 320T / 325T

Operating weight: 7,253-12,364 lb (3,290-5,608 kg) Gross rated power: 74 hp (55 kW)

**JCB North America**

2000 Bamford Blvd., Pooler, Georgia, 31322 Tel: (912) 447-2000

Download the very latest information on this product range at [www.jcb.com](http://www.jcb.com)

JCB inc. All rights reserved. No part of this publication may be reproduced, stored in a retrieval system, or transmitted in any form or by any other means, electronic, mechanical, photocopying or otherwise, without prior permission from JCB inc. All references in this publication to operating weights, sizes, capacities and other performance measurements are provided for guidance only and may vary dependant upon the exact specification of machine. They should not therefore be relied upon in relation to suitability for a particular application. Guidance and advice should always be sought from your JCB Dealer. JCB reserves the right to change specifications without notice. Illustrations and specifications shown may include optional equipment and accessories. The JCB logo is a registered trademark of J.C. Bamford Excavators Ltd.

Your nearest JCB Dealer

