

## SPECIFICATION

**JCB E-TECH**



## ELECTRIC COMPACT TELEHANDLER | 505-20E

Battery capacity: 96V 24kWh Zero Emissions. Lithium-ion Technology.

**JCB**

# 100% electric. Zero emissions.

JCB is leading the way in clean technology and reducing harmful emissions. That's why we are introducing JCB E-TECH, a new generation of electric products with zero emissions at point of use that don't compromise on performance. The new 505-20E is the first of the electric generation and JCB's first fully electric compact telehandler. It lets you do a full day's work on a single charge, giving you access to a whole new world of possibilities.



**ZERO EMISSIONS.**  
The new 505-20E compact telehandler is part of JCB's 100% electric E-TECH range, with zero emissions, less noise and zero compromise on performance.



## LOW NOISE.

Low noise levels make the new 505-20E ideal for working in urban areas, indoors, out of hours and operating in sensitive environments.

## SAFER WORKING.

No trailing tethers, zero emissions, low noise levels and other innovative features provide peace of mind for working safely and efficiently.



## ZERO COMPROMISE.

Get the same high performance as a conventional machine with powerful lithium-ion technology. A 24kWh battery powers the machine for a full day's work.

## REDUCED COSTS.

The new 505-20E has considerably lower operating costs with maintenance-free batteries, minimal daily checks and less servicing.

STATIC DIMENSIONS

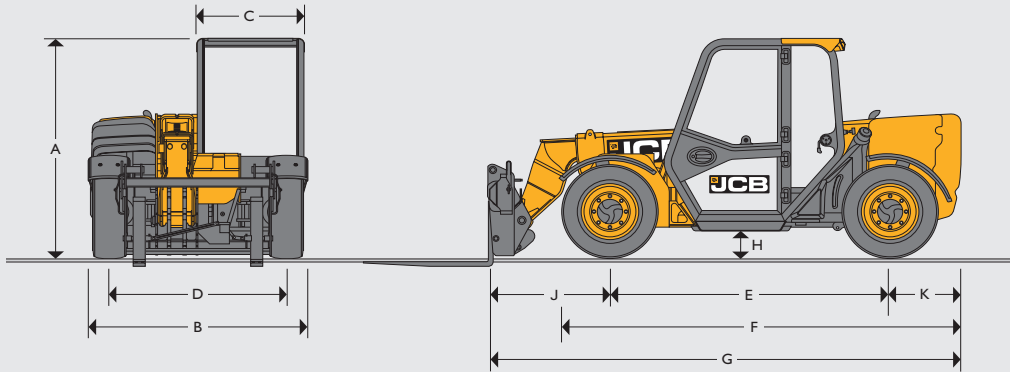

A	Overall height*	ft-in (m)	6-2 (1.89)
B	Overall width (over tires)*	ft-in (m)	6-0 (1.84)
C	Inside width of cab	ft-in (m)	2-10 (0.88)
D	Front track	ft-in (m)	5-0 (1.53)
E	Wheelbase	ft-in (m)	7-10 (2.39)
F	Overall Length to front tires	ft-in (m)	11-1 (3.38)
G	Overall length to front carriage	ft-in (m)	13-1 (4.0)
H	Ground clearance	ft-in (m)	0-8 (22)
J	Front wheel center to carriage	ft-in (m)	1-11 (0.6)
K	Rear wheel centre to rear face	ft-in (m)	0.6
	Outside turn radius (over tires)	ft-in (m)	3.7
	Carriage roll back angle	degrees	11
	Carriage dump angle	degrees	114
	Weight	lb (kg)	11,464 (5200)
	Tires	Industrial	12x16.5

\*Dependant upon tire specified.

LIFT PERFORMANCE

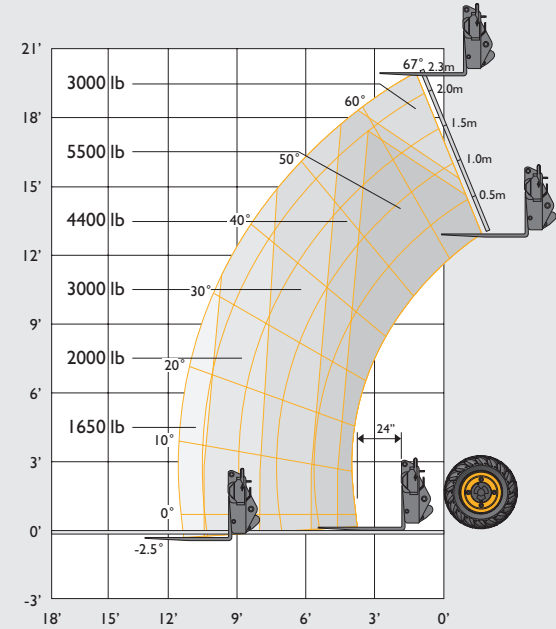

Maximum lift capacity	lb (kg)	5,500 (2500)
Lift capacity to full height	lb (kg)	3,000 (1,360)
Lift capacity at full reach	lb (kg)	1,650 (748)
Lift height	lb (kg)	20-0 (6.0)
Reach at maximum lift height	ft-in (cm)	-0-5 (-15)
Maximum forward reach (to front of carriage)	ft-in (m)	11-0 (3.5)

Complies with stability test ANSI B56.6

**POWER SOURCE**

Battery type	Lithium-ion
Gross capacity	24kWh
System voltage	96V
Manufacturer	Jungheinrich

**CHARGING**

On-board charger allowing direct connection to AC 240, 16 AMP mains power supply.

Run time (application dependent)	8 hour work day; 3.5 hours continuous
On-board charging 1.2kW (120V / 15A)	25 - 80%: 11hrs 0 - 100%: 18hrs
Charging cable plug type	16A 110V - Standard 16A 240V - Optional

**MOTORS**

	Traction	Hydraulic
Motor type	3 phase AC (induction)	3 phase AC (induction)
Motor power	23 HP (17kW)	30 HP (22kW)
Max speed	6000rpm	3000rpm
Peak torque	220Nm	130Nm
Manufacturer	Jungheinrich	Jungheinrich

**HYDRAULICS**

Internal gear pump, fitted with suction strainer and filter. Smart hydraulics on lower and retract with separate filtration on pilot services. Optional boom end aux services.

Operating System Pressure	psi (bar)	3553 (245)
Max flow at system pressure	gal/min (l/min)	17 (65)
Auxiliary Flow	gal/min (l/min)	21 (80)
Hydraulic cycle times	Seconds	
Boom raise		9.9
Boom lower		6.2
Boom extend		10.3
Boom retract		10.0
Bucket dump		4.5
Bucket crowd		4.5

**TRANSMISSION**

Permanent 4WD transmission with independent drive motor and regenerative braking.

		<b>Forward</b>	<b>Reverse</b>
Speed	mph (kph)	9 (15)	9 (15)

**ELECTRICS**

System voltage	Volt	12v/96v
----------------	------	---------

**NOISE AND VIBRATION**

Measurement conditions			
Noise at the operator station	(LpA)	75	Determined in accordance with the test method defined in EN12053.
Noise emission from the machine	(dBA)	93.6	Guaranteed equivalent sound power (external noise) determined in accordance with the dynamic test conditions defined in 2000/14/EC.
Whole body vibration	ft/s <sup>2</sup> (m/s <sup>2</sup> )	4.1 (1.24)	ISO 2631-1:1997 normalized to an 8h reference period and based upon a test cycle defined in SAE J1166.
Hand-arm vibration	ft/s <sup>2</sup> (m/s <sup>2</sup> )	4.2 (1.27)	ISO 5349-2:2001 dynamic test conditions.

**SERVICE FILL CAPABILITIES**

Hydraulic system	gal (l)	11.8 (45)
------------------	---------	-----------

**AXLES**

Front and rear drive JCB axles: epicyclic hub reduction drive/steer axles.

**BRAKES**

Service brakes: Hydraulically operated self-adjusting.

Parking brake: SAHR Handbrake self adjusting operated by in-cab switch.

**BOOM AND CARRIAGE**

Boom is manufactured from high tensile steel. Low maintenance, hard wearing pads.

**Coupler options:** JCB Q-Fit, JCB Compact Tool Carrier and Skid Steer

**STEERING**

Hydrostatic power steering with power track rods on both axles.

**Three steer mode options:** Front wheel steer, all wheel steer, crab steer, operated from in the cab by a selection lever.

**OPERATOR STATION**

Quiet, safe and comfortable cab conforms to ROPS ISO 3471 and FOPS ISO 3449. Single lever servo joystick, incorporating forward/neutral/reverse, with progressive extend/retract and auxiliary functions. Display includes battery charge, hour meter, road speed indicator, clock.

**STANDARD FEATURES**

- Fenders
- White Noise Reverse alarm
- LiveLink telematics
- 110v On-board Charger
- Front Work Lights (LED)
- Amber Beacon (LED)
- Single auxiliary port
- 3 in. Orange seat belt
- Recovery hitch
- Battery isolator
- Face Fan
- Safety Strut

**OPTIONS**

- Cab or Canopy
- Various Attachments
- Pneumatic, semi-solid, non-marking or turf tires
- Front end coupler: Q-Fit, Compact Tool Carrier, Skid Steer
- Road Lights
- Work Lights (LED)
- White Noise Alarm
- Front and Roof Screen Guards
- Radio Ready (Speakers Only)
- Head Light Guards
- Sunblind
- Adjustable Steering Column



100% Electric. Zero emissions.

Your nearest JCB Dealer

**Electric Compact Telehandler 505-20E**

Battery capacity: 96V 24kWh Zero Emissions. Lithium-ion Technology.

**JCB North America**

2000 Bamford Blvd., Pooler, Georgia, 31322 Tel: (912) 447-2000

Download the very latest information on this product range at [www.jcb.com](http://www.jcb.com)

JCB inc. All rights reserved. No part of this publication may be reproduced, stored in a retrieval system, or transmitted in any form or by any other means, electronic, mechanical, photocopying or otherwise, without prior permission from JCB inc. All references in this publication to operating weights, sizes, capacities and other performance measurements are provided for guidance only and may vary dependant upon the exact specification of machine. They should not therefore be relied upon in relation to suitability for a particular application. Guidance and advice should always be sought from your JCB Dealer. JCB reserves the right to change specifications without notice. Illustrations and specifications shown may include optional equipment and accessories. The JCB logo is a registered trademark of J.C. Bamford Excavators Ltd.

DWUSA 5586.2

 JCBNA  @JCBNA  JCBNORTHAMERICA  JCBNA

