

TELEHANDLER

||| STH844A

PERFORMANCE

PERFORMANCE		
Maximum Lift Capacity	8,000 lbs	3,629 kg
Lift Capacity at Maximum Height	6,000 lbs	2,722 kg
Lift Capacity at Maximum Reach	1,500 lbs	681 kg
Boom (Raise/Lower)	13 / 13 sec.	
Boom (Extend/Retract)	16 / 16 sec.	
Frame Leveling	+/- 10 degrees	
Maximum Drive Speed	14 mph	23 kph
Outside Turning Radius (4WS)	14' 1"	4.30 m
Auxiliary Hydraulic Flow	17 gpm	63 L/min
Auxiliary Hydraulic Pressure	2,466 psi	17 MPa
Standard Tire Size	13.00-24	

STANDARD FEATURES

- ➔ No DEF required
- ➔ Wide angle rear view camera
- ➔ Reverse object detection
- ➔ Bright LED work light package
- ➔ Powerful Deutz engine

74 hp
Gross Power
44'
Max Lift Height
8,000 lbs
Max Lift Capacity
25,647 lbs
Operating Weight

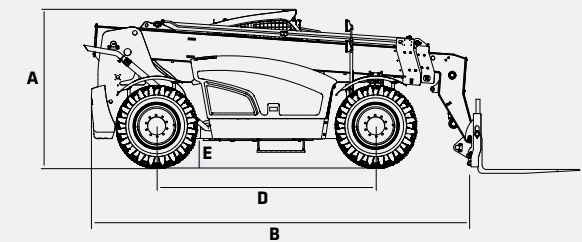
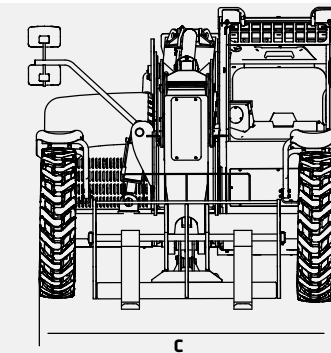
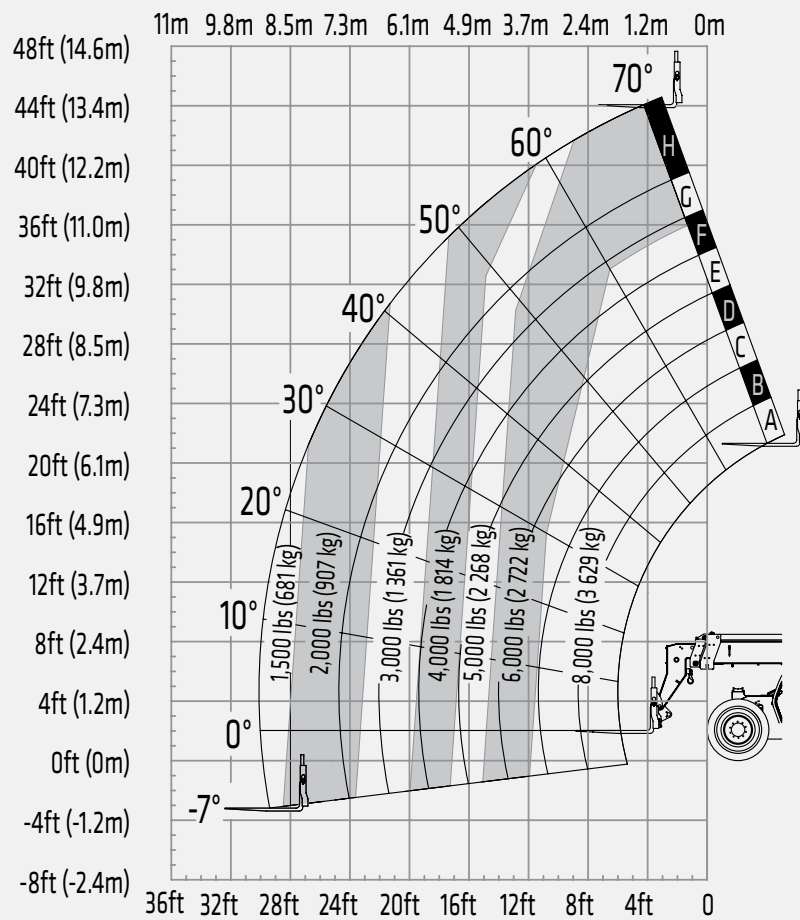

DIMENSIONS

DIMENSIONS		
Maximum Lift Height	44' 0"	13.40 m
Maximum Forward Reach	30' 0"	9.15 m
A Height, Stowed	8' 4"	2.54 m
B Length, Stowed (without Forks)	20' 2"	6.15 m
c Width	8' 1"	2.46 m
d Wheelbase	11' 3"	3.42 m
E Ground Clearance (Center)	1' 6"	0.46 m
Ground Clearance (Axle)	1' 5"	0.43 m
Weight	25,647 lbs	11,633 kg

TECHNICAL SPECIFICATIONS

CAPACITIES		
Gross Power	74 hp	55 kW
Torque	360 lbf-ft	488 Nm
Electrical System	24 volt	
Hydraulic Tank Capacity	33 gal	124 L
Hydraulic System Capacity (with Tank)	42 gal	159 L
Fuel Tank Capacity	36 gal	135 L
COMPONENTS		
Engine	Deutz TCD 3.6	
Transmission	Dana VDT12000	
Axles F/R	Dana 212 / 212	
Hydraulic Pump	Kawasaki Load Sense Piston Pump	
Hydraulic Manifold	Parker	

* Indicates load limited by hydraulic lifting capacity.

In the interest of continual equipment development, SANY America Inc. reserves the right to change these specifications at any time without prior notification.
©2023 SANY America Inc. HEXPS235TH844A001

SANY America Inc. 318 SANY Way
Peachtree City, Georgia 30269
470.552.SANY sanyamerica.com



*Based on theoretical calculation at max flow with no load. Subject to alterations. In the interest of continual equipment development, SANY America Inc. reserves the right to change these specifications at any time without prior notification.
©2023 SANY America Inc. HEXPS235TH844A001



STANDARD AND OPTIONAL EQUIPMENT

s = standard / o = optional

STH844A	ENGINE
s	Exhaust aftertreatment (DPF only, NO DEF)
POWERTRAIN	
s	Powershift transmission
s	Planetary limited slip axles
s	Full-time 4 wheel drive
s	Gear selector lever (Steering-column)
s	Manual shift
s	Service brake, 4-wheel, wet-disc, spring applied, hydraulic release
s	Parking brake, same as service brake
s	Cushioned solid tires
HYDRAULIC	
s	Full variable load-sensing system
s	Single Electric Over Hydraulic Joystick Control
s	Axial piston pump
s	Hydraulic quick coupler lines for auxiliary hydraulics
s	Self-leveling forks
s	Three driver-selectable steering modes (2W, 4W, 4W-Crab)
CABIN	
s	ISO certified ROPS/FOPS Canopy
s	Emergency hammer (closed cabin only)
s	Rubber isolated cab mounts

In the interest of continual equipment development, SANY America Inc. reserves the right to change these specifications at any time without prior notification.
©2023 SANY America Inc. HEXPS23STH844A001



*Warranty applies to 2023 Crane, Telehandler, Grader and Roller models only.



STANDARD AND OPTIONAL EQUIPMENT

s = standard / o = optional

STH844A	ENGINE
o	Fully enclosed cab with automatic heat and air conditioning
s	Digital instrument display
s	Mechanical suspension seat
s	Seat belt, 3" retractable
s	Dual armrests
s	Rear-view camera
s	2-speed fan
s	Dedicated display for rear-view camera
ELECTRICAL	
s	24V electrical system
s	2-12V batteries
PRODUCTIVITY	
s	Back up camera
s	Reverse sensing system
s	Full 4-wheel fender package
s	LED work lights on cab and boom
s	Flashing beacon
s	Lifting hook
s	Frame leveling 10 degrees side to side
s	Rear-Axle stabilization system

In the interest of continual equipment development, SANY America Inc. reserves the right to change these specifications at any time without prior notification.
©2023 SANY America Inc. HEXPS23STH844001

